

Stenhøj Mobile 72

Stenhøj Mobile 72 Wireless

Electro-hydraulic mobile lift

The STENHØJ Mobile 72 Wireless can be delivered in sets of 4, 6, 8 and 10 columns. Each column is manufactured as a control column. The lift can be operated from each column with the integrated control panel with LCD screen display.

The display shows: active columns within the lift set, active operation mode, height in cm, the battery capacity and the quality of the radio communication signal.

The hydraulic cylinders on the columns are self-lubricating and the cylinder rods are encased by steel tubes. The power source is batteries with a total capacity of 110 Ah.



Positioning wheels:

- On each column.
- Rear: wheel jack, spring-loaded, with locking brake.
- Front: Fixed wheels Ø125 mm.

Wireless:

- Simple and quick charging system of batteries.

Adjustable wheel forks:

155R13 – 13R22.5,
ø550 – 1140 mm.

Length of fork 300 mm.



STENHØJ
lifting the level

Stenhøj Mobile 72

The batteries are environmentally safe and maintenance free. The number of lift cycles on charged batteries are approx. 20 with full load or 30 with half load. It takes approx. 8 hours to recharge a flat battery and approx. 30 min. to recharge 1 lift cycle. Lifetimes of the batteries are approx. 3 years.

The batteries can be charged permanently or during operation allowing for full battery standby. Charging cables are mounted on each column to plug in to one mains or at the next column. One single mains supply is sufficient to charge the complete lift set.



STENHØJ
lifting the level

Technical data

Lifting capacity	7200 kg per post (4- or 6-post lifts)
Lifting time	90 sec.
Lowering time	90 sec.
Stroke	1700 mm
Drive	Electro-hydraulic
Connection	230V AC, 50Hz, 4A (for battery charger)
Weight	610 kg
Motor	2.2 kW (per column)
Protection class	IP 65 (Protected against low pressure water jets from any direction) IP 44 (protected against water sprays from all directions – during charging of batteries)

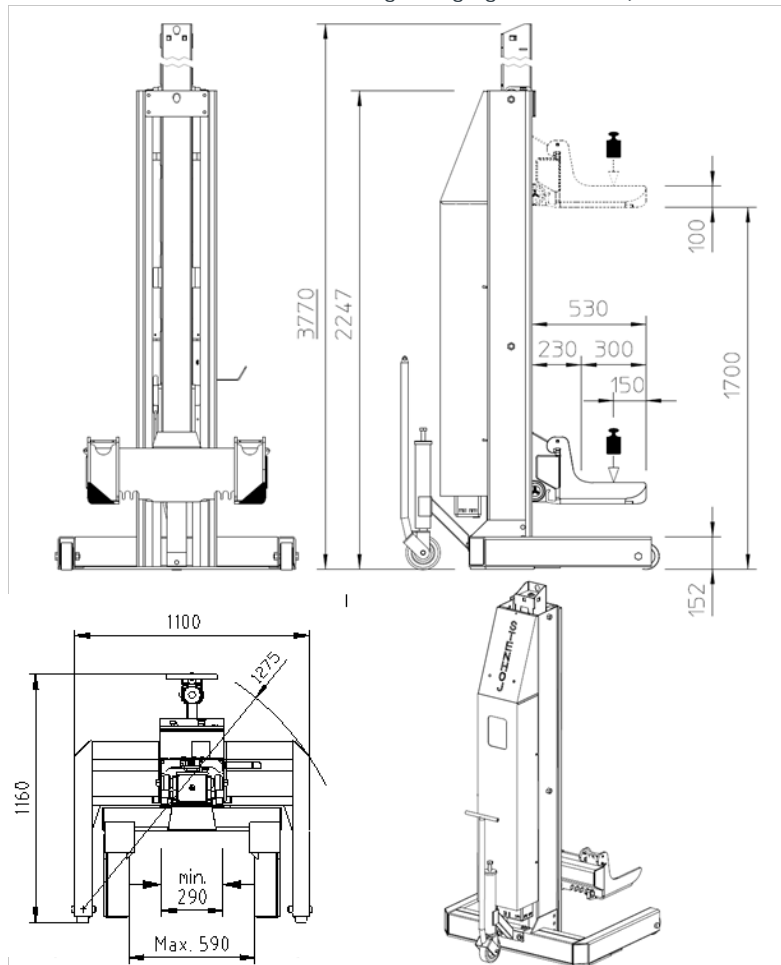

Standard colours

Red RAL 3013
White RAL 9002

No liability accepted for specifications, which are subject to alteration.

Stenhøj A/S
Denmark

Tel: +45 76 82 13 30
Fax: +45 76 82 13 31
Mail: info@stenhoj.dk
Web: www.stenhoj.dk